

(12) **UK Patent Application** (19) **GB** (11) **2 308 320** (13) **A**

(43) Date of A Publication **25.06.1997**

(21) Application No **9626010.4**

(22) Date of Filing **13.12.1996**

(30) Priority Data

(31) **9526489** (32) **22.12.1995** (33) **GB**

(71) Applicant(s)

Pifco Limited

(Incorporated in the United Kingdom)

**Failsworth, MANCHESTER, M35 0HS,
United Kingdom**

(72) Inventor(s)

**Geoffrey Norman Walter Gay
George Griffiths**

(74) Agent and/or Address for Service

**Roystons
Tower Building, Water Street, LIVERPOOL, L3 1BA,
United Kingdom**

(51) INT CL⁶
B03C 3/02 3/28

(52) UK CL (Edition O)
**B2J JD1 JG J101 J202 J204
U1S S1272**

(56) Documents Cited
US 5268009 A US 5035728 A

(58) Field of Search
UK CL (Edition O) **B2J JD1 JM**
INT CL⁶ **B03C 3/02 3/28**
On-line:WPI

(54) **Electrostatic air filtration apparatus**

(57) Air filtration apparatus comprises an inlet 14, an outlet 16, a fan 18, a corona discharge cell 20 and an electret filter 22 e.g. polypropylene. In another embodiment, Figure 3, two discharge cells (40, 44) are provided in sequence, and two electret filters (42, 46) the first being thicker than the second. The return current from the filter element (54 Figure 4) can be measured to give an indication of levels of pollutant particles present, the indication being used to control the speed of the fan and show when the filter needs to be replaced.

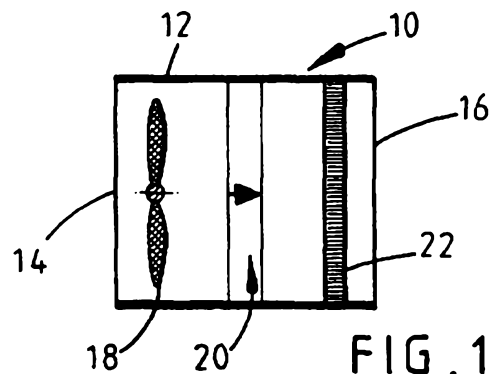

1-2

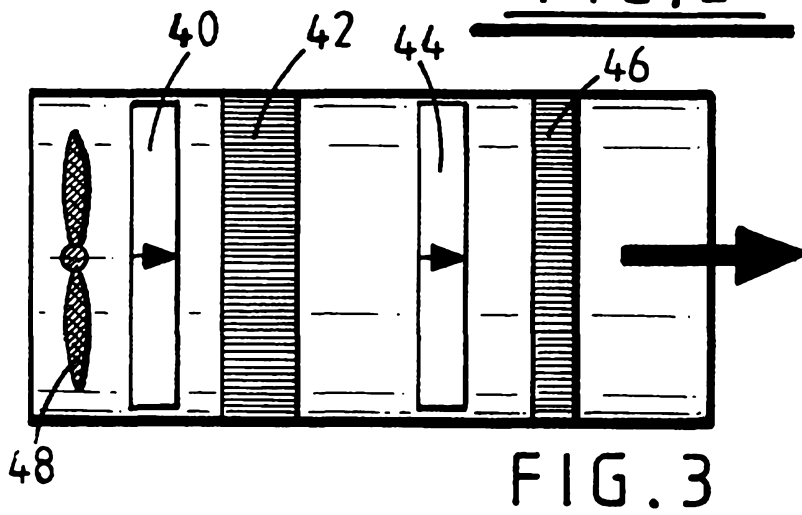
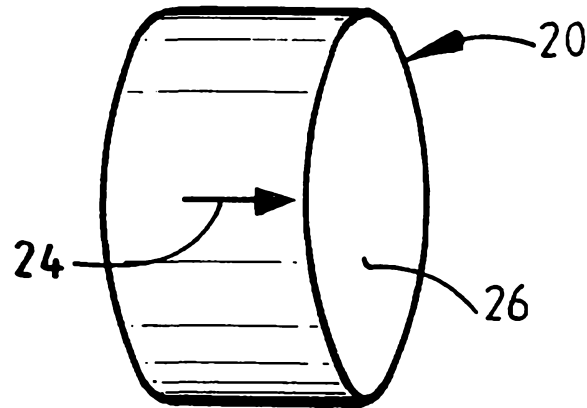
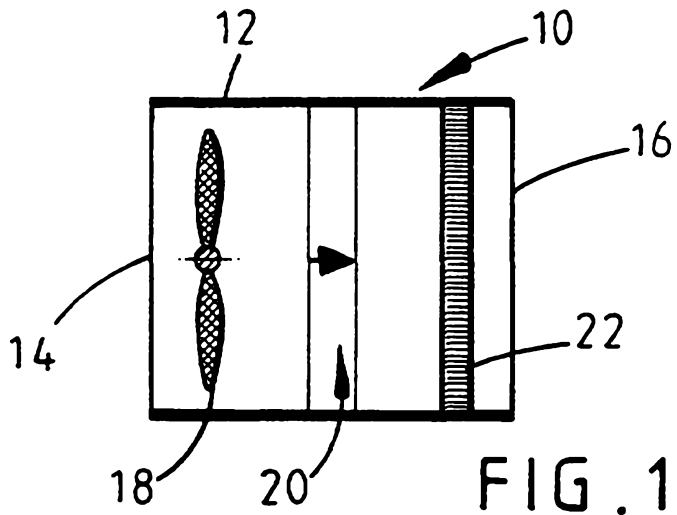

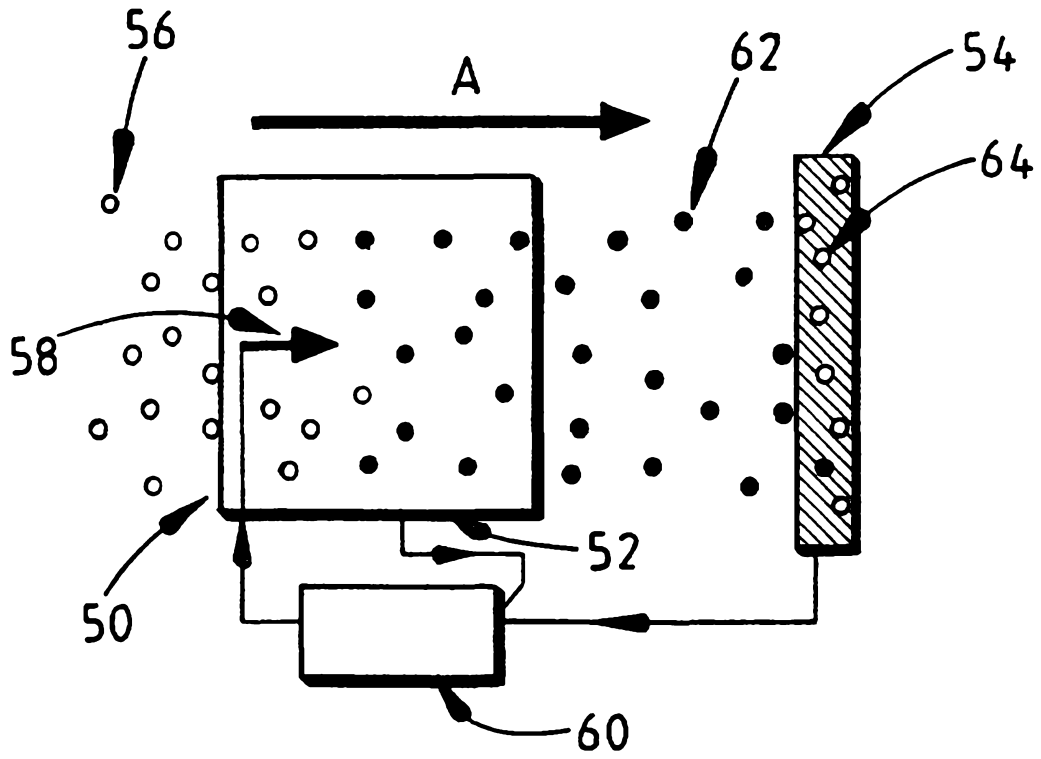

FIG. 4

TITLE: Air filtration apparatus.

DESCRIPTION

This invention concerns air filtration apparatus.

There are two main methods of cleaning air of respirable pollutant particles at high efficiency. The first method is to use a mechanical filter of fine fibres, typically glass fibres. By this method filtration efficiencies of up to 99.97% may be achieved but with the drawback of very high pressure drop across the filter.

The second main filtration method uses a filter composed of electret fibres which have electrical charges embedded therein. These electrical charges exert an attractive force on airborne particles, causing them to be trapped in the filter more efficiently than an equivalent non-electret filter. These filters have a lower pressure drop but can only practically achieve filtration efficiencies of up to about 95%.

An object of this invention is to provide an improved air filtration apparatus.

According to the present invention there is provided air filtration apparatus comprising corona discharge means connected to a high voltage source for electrically charging pollutant particles passing through the apparatus and an electret filter member for collecting charged pollutant particles.

The apparatus of the invention preferably further comprises means for drawing air through the apparatus to pass through the filter. Typically an

electrically operated fan will be provided for that purpose. The fan may be upstream or downstream of the filter member.

In one preferred embodiment the corona discharge means comprises corona wires and/or plates with a high voltage between them, typically in the range of from $\pm 3,000$ volts to $\pm 20,000$ volts. In another more preferred embodiment the air stream is passed through a tube having a corona discharge electrode within it with a high voltage between the tube and the electrode. That arrangement is hereinafter referred to as a "cell". The tube is preferably circular in section and the electrode is preferably on its central longitudinal axis. The tube preferably has its inner surface of or coated with conducting material, such as of copper, and the conducting surface is preferably held at a different voltage from the discharge electrode by $\pm 3,000$ volts to $\pm 20,000$ volts. The inner surface of the tube is preferably connected to the low voltage side of the high voltage source. The apparatus of the invention may comprise a plurality of cells each having its own associated electret filter or common electret filter. The cells may be in a parallel or in series. In the latter case an electret filter member is preferably provided after each cell.

A single point source of charge in each cell of the apparatus of the invention surrounded by a discharging electrode has the advantage of producing a flow of charging air ions emanating from the point and flowing orthogonally across the path of the pollutant particles through the apparatus. The flow of such ions is substantially even, radially of the point to provide symmetry of air ion flux with respect to the particle flow. In that way there

is very little chance of a pollutant particle passing through the apparatus without receiving a charge and hence not being collected by the electret filter.

The electret filter member is preferably composed of electret fibres, which are typically of plastics material, such as polypropylene. The electret filter member may comprise a woven or non-woven web of electret fibres. Electret fibres have electrical charges embedded therein or thereon.

In a simple preferred embodiment of the invention an air filter apparatus comprises a casing having an inlet and an outlet for air to pass through the apparatus and in sequence a fan, a corona discharge cell and an electret filter member.

It is preferred, however, in order to improve filtration efficiencies further to have, along with means for drawing air through the apparatus, such as a fan, two or more filter members preferably composed of electret fibres each preceded by a corona discharge cell for electrically charging air pollutant particles.

In such an arrangement it is preferred that a first filter member be relatively thick compared to the or each subsequent filter member although filter members of similar thickness may be used. The thicker filter member is aimed to give practical filter life, whereas the second and subsequent thinner filters improve efficiency without undue increase in pressure drop across the filter apparatus. With arrangements of this type it is envisaged that filter efficiencies between 99.98 and 100% may be achievable.

With regard to the preferred corona discharge system comprising a

cylindrical tube with a central electrode, the inner surface of the tube being conductive, that has the advantage that virtually all light air ion flux is collected by the conducting surface, typically connected to the low voltage side of the high voltage source, so that virtually no flux escapes from the apparatus that would otherwise cause dirt deposition on the surroundings. In addition, due to this substantially complete capture of air ions in the charging cell, the only charge escaping the charging cell and subsequently impinging on the filter is the charge carried by the pollutant particles. These are substantially totally captured by the filter, so that the charge collected can be measured.

A path for return of charge collected on the filter to the high voltage generator is preferably provided, whereby the amount of pollutant particles collected by the apparatus may be measured. It is, therefore, preferred that the filter apparatus of the invention include means for measuring current returning from the filter to the high voltage generator.

The current measured in that way may be used as a signal to aid operation of the filter apparatus. For example, the return current indicates the amount of pollution present and so the signal may be used to control fan speed to increase or reduce air throughput accordingly. Alternatively, operation of the filter apparatus may be cycled to target a preset level of pollution.

The signal may be used to provide an instantaneous rate of collection of pollution particles in order to ascertain whether or not the apparatus is working.

Thirdly, the signal may be used to provide an aggregate of charge collected so as to indicate exhaustion of the filter for timely replacement.

This invention will now be further described, by way of example only, with reference to the accompanying drawings, in which:-

Figure 1 shows schematically an air filter according to the invention;

Figure 2 shows schematically a corona discharge system;

Figure 3 shows schematically another air filter according to the invention; and

Figure 4 is another schematic drawing of air filter apparatus of the invention.

Referring to Figure 1 of the accompanying drawings, an air filter 10 has a casing 12 with an inlet 14 and an outlet 16. In sequence from the inlet 14 are a fan 18, a charging zone or cell 20 and a filter element 22.

The fan 18 is simply an electrically driven fan to draw air through the air filter inlet 14 and out through the outlet 16.

The charging zone 20 is provided to impart a charge to pollutant particles in the air passing through the air filter. Various means may be used for charging the pollutant particles. The charging zone may comprise wires and/or plates with a high voltage between them, typically of the order of $\pm 3,000$ to $\pm 20,000$ volts, to produce a corona discharge.

An alternative particle charging system 20 (see Figure 2) comprises a corona discharge electrode 24 in a tube 26, the inner surface of which is of conducting material. The inner surface of the tube is held at a different

voltage to the corona discharge electrode by $\pm 3,000$ to $\pm 20,000$ volts and is typically connected to earth. The tube 26 is cylindrical and the electrode 24 is on its longitudinal central axis.

The filter element 22 is preferably composed of so-called electret fibres. These fibres have embedded therein isolated positive and negative charges. Typically the fibres are made of polypropylene.

Air is drawn into the filter by the fan 18 and is charged in the charging zone including dirt particles therein. The corona electrode produces light aero-ions with a high mobility in the electric field. These aero-ions pass across the charging zone colliding with pollutant particles to impart electrical charge thereto. Substantially all of the aero-ions are retained within the charging zone by virtue of their high mobility and the influence on them of the electric field within the charging zone. The charged pollutant particles by virtue of their greater mass will have a lower mobility in the electric field and will pass completely out of the charging zone and be attracted to the electret fibres of the filter 22, where they experience greater attraction than if uncharged, whereby filtration is enhanced. The pressure drop across the filter may also be relatively low.

The charge on the trapped particles can be caused to flow back to the high voltage generator via the filter 22 and an electrical measuring circuit and indicator to give an indication of the degree of air cleaning and the pollution level in the air. Such an arrangement is shown in Figure 4 of the accompanying drawings discussed below.

In the embodiment illustrated in Figure 3 of the accompanying

drawings instead of a single corona discharge zone/filter combination, two such combinations 40, 42 and 44, 46 are provided along with a fan 44. The first filter 42 is thicker than the second filter 46 to provide a practical filter lifetime and the second relatively thin filter 46 does not unduly increase the pressure drop across the air filter itself whilst enhancing filtration by removing the relatively low concentration of pollutant particles which have penetrated the first filter. The corona discharge zones 40 and 44 and the filters 42 and 46 are of the types described in relation to the embodiment of Figure 1. Filtration efficiencies between 99.98 and 100% may be achieved with this arrangement.

Finally, Figure 4 of the accompanying drawings has been included to demonstrate return of charge from a filter element whereby the return current can be usefully measured. Figure 4 shows filter apparatus 50 having a corona cell 52 and an electret filter element 54, whereby pollutant particles 56 entering the apparatus and travelling in the direction of arrow A, drawn or propelled by a fan (not shown), are charged by collision with air ions produced by corona discharge needle 58 in the cell 52. The corona discharge is generated by high voltage generator 60 connected to the needle 58. The cell 52 has a conductive lining connected to the low voltage side of the generator, whereby air ions are drawn thereto and discharged, so that they do not escape from the cell.

The resultant charged particles 62 are collected on the electret filter element 54, typically of the type described for the other illustrated embodiments and their charge given up (64). The filter element is connected

to the high voltage generator 60 so that the charge on the filter can return as a measurable current to the generator.

The current measured can be used for a number of purposes. The amount of charge collected on the filter element indicates the level of pollutant particles present. Therefore, the current measured can be used to control the fan speed in variance with the level of pollution.

Current measurement may be used to indicate instantaneous rate of capture of pollutant particles, thus signalling whether the apparatus is working. The current could be used, for example, to power a visual display, such as an L.E.D., to show that the apparatus is working.

The current measurement can also be continuously aggregated, in order to indicate the total amount of pollutant particles collected and hence when the filter element is likely to be exhausted. Again this measurement may be used to power a visual display, such as an L.E.D. to show when the filter element needs replacing.

The apparatus of the invention has a number of advantages that deserve mention. By charging pollutant particles from a single corona discharge point in a cell, virtually no particles can pass through the cell without being charged. Hence the apparatus of the invention can operate at very high efficiency levels even up to 99.999% efficiency.

Secondly, by collecting air ions and discharging same via the cell wall surrounding the corona electrode, virtually no electric field impinges on the electret filter to hinder its operation.

Thirdly, as virtually all the charge particles are collected as well as

the air ions, virtually no charge escapes from the apparatus to cause charge build up and hence dirt collection on surfaces around the apparatus.

CLAIMS

1. Air filtration apparatus comprising corona discharge means connected to a high voltage source for electrically charging pollutant particles passing through the apparatus and an electret filter member for collecting charged pollutant particles.
2. Apparatus as claimed in claim 1, further comprising means for drawing air containing pollutant particles through the apparatus to pass through the filter.
3. Apparatus as claimed in claim 1 or 2 comprising a casing having an inlet and an outlet for air to pass through the apparatus and, in sequence, a fan, a corona discharge zone and an electret filter member.
4. Apparatus as claimed in claim 1, 2 or 3 comprising two or more filter members, each preceded by a corona discharge means.
5. Apparatus as claimed in claim 4, wherein a first filter member is relatively thick compared to one or each subsequent filter member.
6. Apparatus as claimed in any one of claims 2 to 5, wherein said drawing means is an electrically operated fan.
7. Apparatus as claimed in any one of claims 1 to 6, wherein the corona discharge means comprises wires and/or plates with a high voltage between them.
8. Apparatus as claimed in claim 7, wherein the high voltage is in the range of from ± 3000 to $\pm 20,000$ volts.
9. Apparatus as claimed in any one of claims 1 to 6, wherein the corona discharge means comprises a tube having a corona discharge electrode within it, with a high voltage between the tube and the electrode.

10. Apparatus as claimed in claim 9, wherein the tube is of circular cross-section and the electrode is on its central longitudinal axis.
11. Apparatus as claimed in claim 9 or 10, wherein the tube has its inner surface of or coated with conducting material.
12. Apparatus as claimed in claim 9, 10 or 11, wherein said high voltage between the conducting surface and the discharge electrode is in the range of ± 3000 to $\pm 20,000$ volts.
13. Apparatus as claimed in claim 12, wherein the conducting surface is connected to earth the low voltage side of the high voltage source.
14. Apparatus as claimed in any one of claims 1 to 13, wherein the electret filter is composed of electret fibres.
15. Apparatus as claimed in claim 14, wherein the electret fibres are of plastics material.
16. Apparatus as claimed in claims 14 or 15, wherein the electret fibres are of polypropylene.
17. Apparatus as claimed in any one of claims 1 to 16, further comprising a path for return of charge collected on the filter to the high voltage source.
18. Apparatus as claimed in claim 17, further comprising means for measuring current returning along said path to the high voltage source.
19. Apparatus as claimed in claim 18, further comprising means for controlling fan speed in response to return current measured.
20. Apparatus as claimed in claim 18 or 19, further comprising means for indicating operation of the apparatus in response to return current measurement.

21. Apparatus as claimed in claim 18, 19 or 20, further comprising means for indicating filter member exhaustion in response to return current measured over a period of time.

22. Air filtration apparatus substantially as hereinbefore described with reference to and as illustrated in any one of the accompanying drawings.



Application No: GB 9626010.4
Claims searched: 1 to 22

Examiner: J L Freeman
Date of search: 24 February 1997

Patents Act 1977
Search Report under Section 17

Databases searched:

UK Patent Office collections, including GB, EP, WO & US patent specifications, in:
UK Cl (Ed.O): B2J (JD1, JM)
Int Cl (Ed.6): B03C (3/02, 3/28)
Other: On-line: WPI

Documents considered to be relevant:

Category	Identity of document and relevant passage	Relevant to claims
X	US 5268009 (P M Thompson & W L Wood) Col 2 lines 6 to 29	1, 2, 6-8, 14 & 15
X	US 5035728 (R C Fang) Col 1 line 59 to col 3 line 19	1, 2, 6-8, 14 & 15

X	Document indicating lack of novelty or inventive step	A	Document indicating technological background and/or state of the art.
Y	Document indicating lack of inventive step if combined with one or more other documents of same category.	P	Document published on or after the declared priority date but before the filing date of this invention.
&	Member of the same patent family	E	Patent document published on or after, but with priority date earlier than, the filing date of this application.